

Aztec Track Master™ Atlas®
Classic RS3, RS11, RSD4/5, RSD12

Track Master™
FRAME TM3020

Tools needed to do the job:

Small Phillips screwdriver / Soldering iron / X-Acto® knife / Ruler / Wire strippers / Safety glasses

- First test the decoder. Follow the instruction manual that comes with the decoder.
- Once you have confirmed that the decoder is operating properly, cut each of the wires coming from the decoder to the lengths given in the following table:

Black	2 1/16"	Yellow	***	Orange	1 7/8"
Red	2 1/16"	White	2 3/16"	Gray	1 1/2"

*** If hooking up rear light cut YELLOW wire to length as needed, otherwise cut as short as possible and insulate.

NOTE: For decoders with a transponder use BLUE wire and cut same length as the WHITE one. Solder to opposite side of light and isolate from frame with a cut in the trace.

- Now strip 1/16" insulation from the end of each wire.
- Completely disassemble the locomotive.

- Make sure to mark motor so you know which is the top.
- Pry the brush holders up from the motor housing and remove the contact strips.
- Solder the ORANGE and GRAY wires to the brush holders as shown in Fig. 1.

NOTE: The soldering of wires to brush holders must be compact to ensure enough spacing to be free of both frame halves.

- Lay the light board out in front of you, parts side down as in Fig. 2. With a sharp hobby knife make a cut in the circuit trace as shown (Fig. 2).

- Attach the BLACK and RED wires as shown (Fig. 3). Solder WHITE wire to front light board.

- Replace the brushes, spring and brush holders (ORANGE wire to bottom of motor).

- Your decoder and motor are now ready to be installed into the Track Master frame. With the left mainframe laid out in front of you (short hood to your right) install the motor with the GRAY wire on the top and ORANGE wire on the bottom. Inspect brush holders and wires to be sure they are not touching frame.

- Install front and rear worm assemblies. Install the front and rear insulating bushings. Place left mainframe on to the right mainframe.

- Install front and rear nuts and screws but do not tighten. Install the truck assemblies. Now tighten screws.

- Install the body with care as it may be a snug fit.

- Test the locomotive as directed in the decoder manual.

NOTE: If locomotive runs in the wrong direction, the motor may be in upside down. Remove brush holders and turn motor over. Replace brush holders and test again.

NOTE: Keep in mind that whenever modifying your locomotive you void the factory warranty.

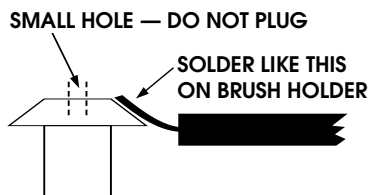

Fig. 1

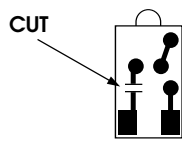

Fig. 2

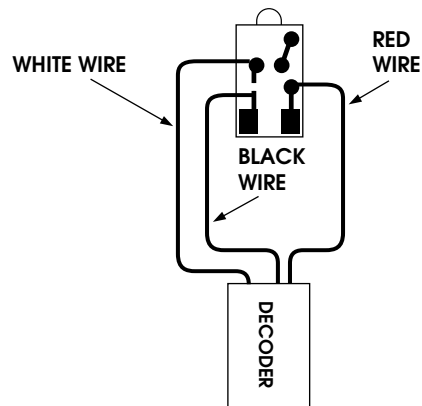

Fig. 3



2701 Conestoga Drive, # 113
 Carson City, NV 89706
 Tel: (775) 883-3327
 Fax: (775) 883-3357
 E-mail: aztecmfg@usa.net
 Website: www.aztectrains.com