

Aztec Track Master™ Atlas® Classic GP30/35

Track Master™ FRAME TM3016

Tools needed to do the job:

Small Phillips screwdriver / Soldering iron / X-Acto® knife / Ruler / Wire strippers / Safety glasses

- First test the decoder. Use the test kit and follow the instruction manual that comes with the decoder.
 - Once you have confirmed that the decoder is operating properly, cut each of the wires coming from the decoder to the lengths given in the following table:
- | | | | | | |
|-------|-----|--------|------|--------|-----|
| Black | 1¾" | Yellow | 7/8" | Orange | 1" |
| Red | 1¾" | White | 1⅞" | Gray | 1⅝" |

NOTE: For decoders with a transponder use BLUE wire and cut same length as the WHITE one. Solder to opposite side of light and isolate from frame with a cut in the trace.

- Now strip 1/16" insulation from the end of each wire.
- Completely disassemble the locomotive.
- Remove the motor from the motor saddle. Make sure to mark motor so you know which is the top. Remove the motor brush retaining caps, being very careful not to lose the springs or brushes.
- Pry the brush holders up from the motor housing and remove the contact strips. Replace the brush holders.
- Solder the ORANGE and GRAY wires to the brush caps.

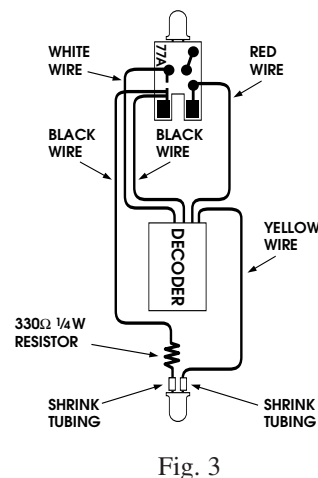
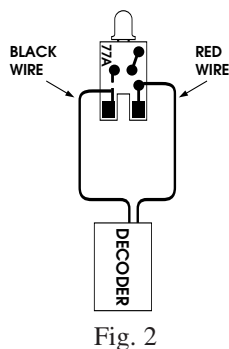
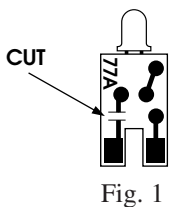

NOTE: The soldering of wires to brush caps must be compact to ensure enough spacing to be free of both frame halves.

- Lay the light board out in front of you, parts side down as shown (Fig. 1). With a sharp hobby knife make a cut in the circuit trace as shown (Fig. 1). Attach the BLACK and RED wires as shown (Fig. 2). Solder WHITE wire to front light board and the YELLOW wire to rear light as shown (Fig. 3).
- IMPORTANT: Make sure to insulate connections to LED. Shrink tubing is recommended (available at Radio Shack).**

- Replace the brushes, spring and retaining caps (ORANGE wire to top of motor).
- Your decoder and motor are now ready to be installed into the Track Master frame. With the right mainframe laid out in front of you (front to your left), install the motor with the GRAY wire on the bottom. The ORANGE wire goes on top. Guide the GRAY wire around the right side of the motor so that it lines up with the groove in the right mainframe. Inspect brush caps and wires to be sure they are not touching frame.
- Pick up the mainframe and look at the back side. The GRAY wire should be lying loose in the groove. Try turning the flywheels. The motor and flywheels should spin freely.
- Install front and rear worm assemblies. Install the front and rear insulating bushings. Again check motor and flywheels for free movement. Place left mainframe on to the right mainframe.
- Install front and rear nuts and screws but do not tighten. Install the truck assemblies. Now tighten screws.
- Install the right and left contact strips and fuel tank.
- Install the body with care as it may be a snug fit.
- Test the locomotive as directed in the decoder manual.

NOTE: If locomotive runs in the wrong direction, the motor may be in upside down. Remove brush wires and turn motor over. Replace wires and test again.

NOTE: Keep in mind that whenever modifying your locomotive you void the factory warranty.



2701 Conestoga Drive, # 113
Carson City, NV 89706
Tel: (775) 883-3327
Fax: (775) 883-3357
E-mail: aztecmfg@usa.net
Website: www.aztectrains.com