

Aztec Track Master™
Atlas® Classic GP7 (late) & GP9

Track Master™
FRAME TM3011

Tools needed to do the job:

Small Phillips screwdriver / Soldering iron / X-Acto® knife / Ruler / Wire strippers / Safety glasses

- First test the decoder. Use the test kit and follow the instruction manual that comes with the decoder.
- Once you have confirmed that the decoder is operating properly, cut each of the wires coming from the decoder to the lengths given in the following table:

Black	2"	Yellow	***	Orange	2 3/8"
Red	2"	White	2 1/4"	Gray	1 1/2"

*** If hooking up rear light cut YELLOW wire to length as needed, otherwise cut as short as possible and insulate.

NOTE: For decoders with a transponder use BLUE wire and cut same length as the WHITE one. Solder to opposite side of light and isolate from frame with a cut in the trace.

- Now strip 1/16" insulation from the end of each of the wires.
- Completely disassemble the locomotive.

NOTE: Care must be taken when removing and installing the body. Do not force.

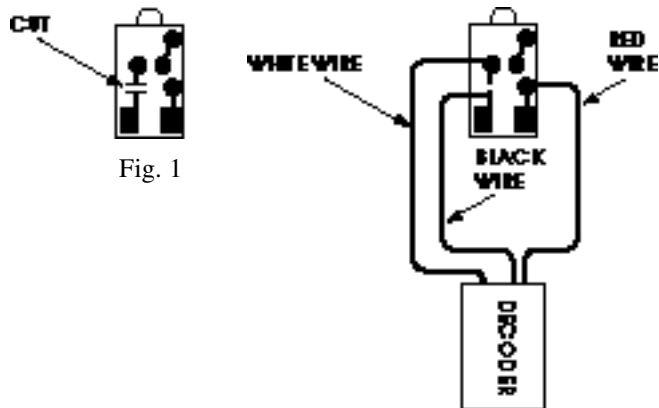

Fig. 2

- Remove the motor from the motor saddle. Make sure to mark motor so you know which is the top. Pry the brush holders up from the motor housing and remove the contact strips and discard. Be careful not to lose the springs or brushes.
- Solder the ORANGE and GRAY wires to the brush holders.

NOTE: The soldering of wires to brush holders must be compact to ensure enough spacing to be free of both frame halves.

- Lay the light board out in front of you, parts side down as shown in Fig. 1. With a sharp hobby knife make a cut in the circuit trace as shown (Fig. 1). Attach the BLACK and RED wires as shown (Fig. 2). Solder WHITE wire to front light board as shown (Fig. 2).

- Replace the brushes, spring and brush holders (ORANGE wire to bottom of motor).
- Your decoder and motor are now ready to be installed into the Track Master frame. With the left mainframe laid out in front of you (front to your right), install the motor with the GRAY wire on the top. The ORANGE wire goes on bottom. Inspect brush wires to be sure they are not touching frame.
- Pick up the mainframe and try turning the flywheels. The motor and flywheels should spin freely.

- Install front and rear worm assemblies. Install the front and rear insulating bushings. Again check motor and flywheels for free movement. Place right mainframe on to the left mainframe.

- Install front and rear nuts and screws but do not tighten. Install the truck assemblies. Now tighten screws.

- Install the right and left contact strips and fuel tank.

- You may have to remove rear light lens. Install the body with care as it may be a snug fit.

- **Test the locomotive as directed in the decoder manual.**

NOTE: If locomotive runs in the wrong direction, the motor may be in upside down. Remove brush holders and turn motor over. Replace brush holders and test again.

NOTE: Keep in mind that whenever modifying your locomotive you void the factory warranty.

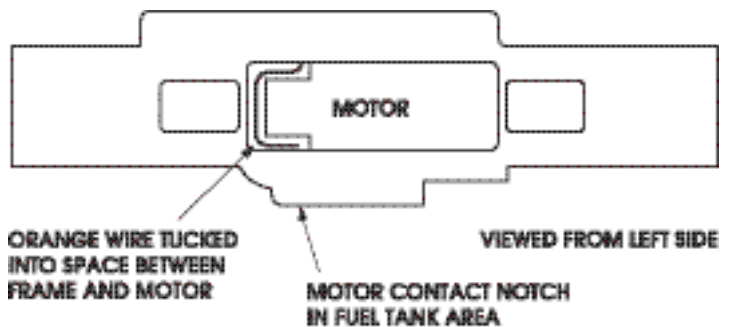

Fig. 3



2701 Conestoga Drive, # 113
 Carson City, NV 89706
 Tel: (775) 883-3327
 Fax: (775) 883-3357
 E-mail: aztecmfg@usa.net
 Website: www.aztectrains.com